

## INSTALLATION INSTRUCTIONS

DESCRIPTION: Billet Clutch Basket Kit

PART NUMBER: GYT-5XD56-10-00

MODEL: '04~YZ450F, '04~WR450F, '16~YZ450FX

# GYTR

 **YAMAHA**  
GENUINE  
Parts & Accessories

### **⚠ WARNING**

Please read and understand these instructions completely before installation to avoid possible injury, or damage to the accessory or vehicle.

### **NOTICES:**

This installation requires a torque wrench and the service manual. It should be performed by an authorized Yamaha dealer or other qualified technician.

### **WARRANTY INFORMATION:**

Genuine Yamaha accessories for YZ and WR models are covered by a 30-day warranty against defects in material or workmanship. Labor for replacement of defective components is not covered. See your Yamaha dealer for a copy of the warranty statement.

### **DEALER OR INSTALLER:**

These instructions contain important information for future reference and *must* be given to the customer.

### **PARTS LIST:**

No.	Part Number	Description	Qty
--	GYT-5XD56-10-00	Billet Clutch Basket Kit	--
①	*	Billet clutch basket	1
②	*	Retainer Plate	1
③	*	Screw M5x0.8x16mm	8

\* Part supplied with kit only and not available separately.

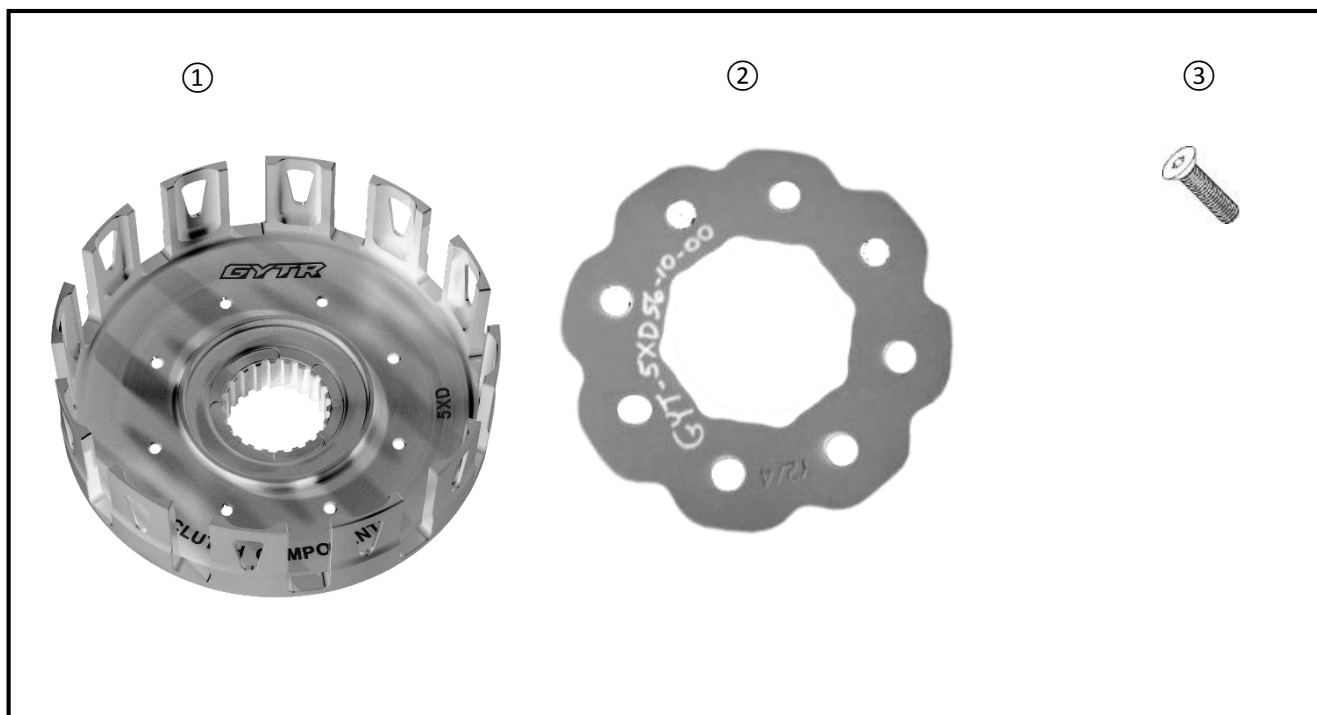

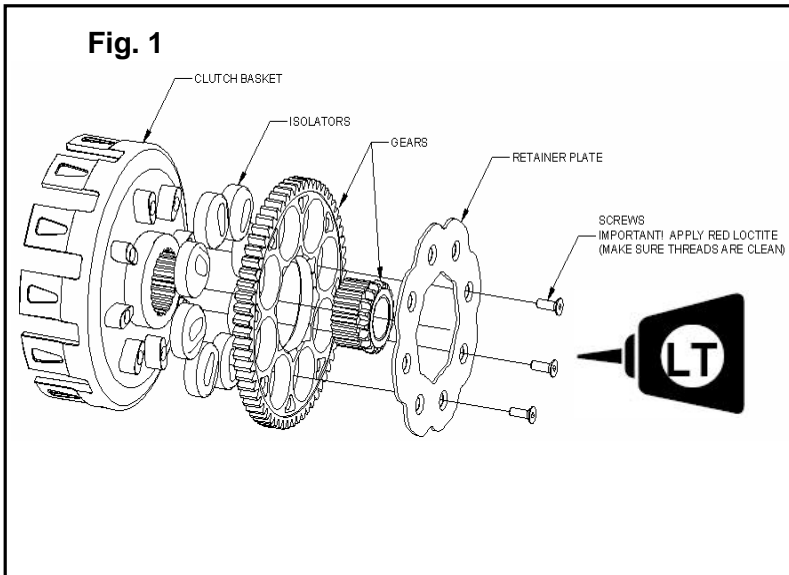

### PREPARATION:

- Stand motorcycle on a secure and level surface.
- Clean all mounting surfaces before beginning installation.

### INSTALLATION:

1. Place motorcycle securely on a bike stand.
2. Remove the clutch basket from the bike by following all the steps in your Yamaha service manual. (LIT-11626-17-45 )
3. Once the basket is removed, center punch and drill the heads of the rivets on the back of the basket to remove the stock retainer plate, stock gears and isolators. Note: mark the orientation of the gears, isolators and retainer plate so they can be re-assembled in the same position as normal wear could have an effect on clutch performance if these items were to get mixed up.
4. Press out OE kick pinion gear from OE Basket. This gear will then need to be pressed back into your GYTR Billet Basket.
5. Install the gears, isolators (text side out) and new retainer plate (item 2) onto your new GYTR basket (item 1) with the 8 screws provided (item 3). Note: Clean the screws and the threads in the basket with contact cleaner.
6. Apply RED LOCTITE to the cleaned screws and tighten to 10Nm-7.4 ft lbs.

You are now ready to reinstall your new clutch basket in your transmission by following the procedure in your Yamaha service manual.

### MAINTENANCE:

For the best performance and life from your clutch assembly, install new OEM clutch plates and Yamalube oil with your new clutch basket. Use of Kevlar plates will cause excessive wear and can void your warranty. Replace your transmission oil often by following the maintenance procedure recommended in your Yamaha owners' manual.

### CARE AND CLEANING:

Clean painted metal parts with a clean soft cloth and mild soap and water. Rinse and dry. Clean the windscreen with a clean soft cloth and mild soap and water solution.

### CUSTOMER SERVICE:

For further information see your Yamaha dealer.

**ESTIMATED TIME TO INSTALL: 0.5 HRS**